

**PRODUCTS
FOR THE**

PRINTING INDUSTRY

APPLICATION GUIDE

NEXEN SOLUTIONS FOR YOUR PRINTING CHALLENGES

Nexen is an internationally recognized industry leader offering a full range of tension and web related products (including sensors, closed or open-loop controls, web guides, splice detection devices, and tension brakes and clutches) as well as comprehensive custom engineering services. Nexen web control systems prevent loss of materials, time and money by providing dependable performance and easy integration.

Nexen also offers products for post-printing operations such as sheeting, die cutting, laminating, inserting, and collating. All systems feature air-engaged clutches and/or brakes to provide the best tensioning in the industry. Nexen has been proving for years that air-engaged products last longer, respond faster, provide more torque and thermal horsepower, and consume less energy than comparable electric units.

Flying Splice Turret

Tension Brakes or Clutches

BTBA, XTBA, STC, TCC, SA, TA

Function: Regulates tension on roll stock as material is fed onto or removed from the press.

Tension Controls

RSTC1000, TC820,
RSD Series Dancer Control System

Function: Controls tension levels before, during and after splicing operations.

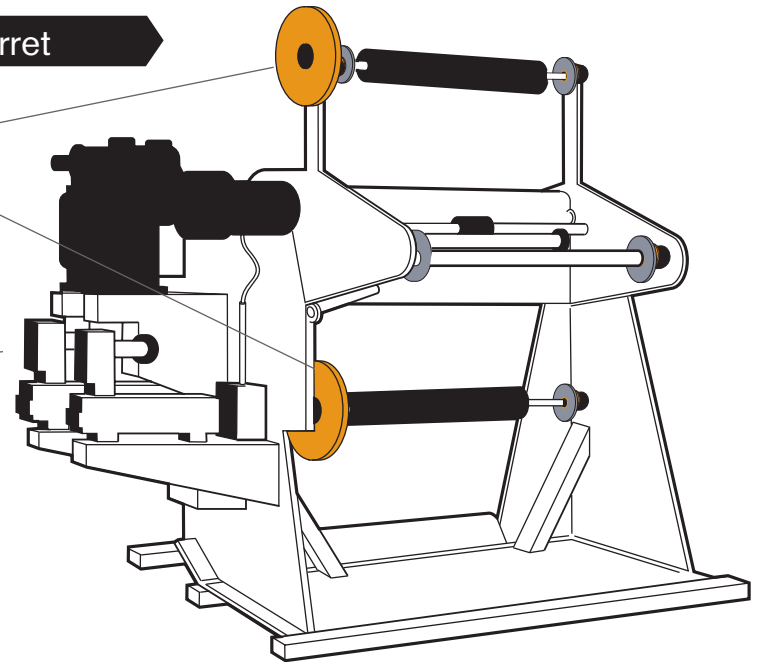

Sheeter

Tension Brakes

BTBA, XTBA, STB, SA, TA

Function: Regulates tension on roll stock as material is fed into the sheeter.

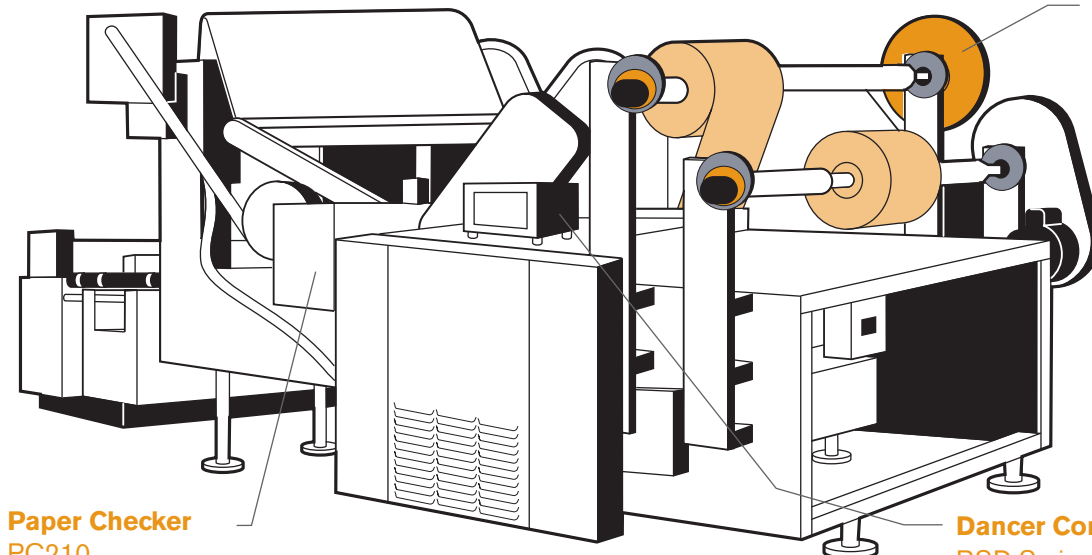

Paper Checker

PC210

Function: Detects spliced stock and signals the machine to discard sheets with splices.

Dancer Control System

RSD Series

Function: Maintains dancer roll position by sending corrective signals to brakes or drives to control tension.

Web Press

Paper Checker

PC210

Function: Detects splices and web breaks to prevent damage to the press.

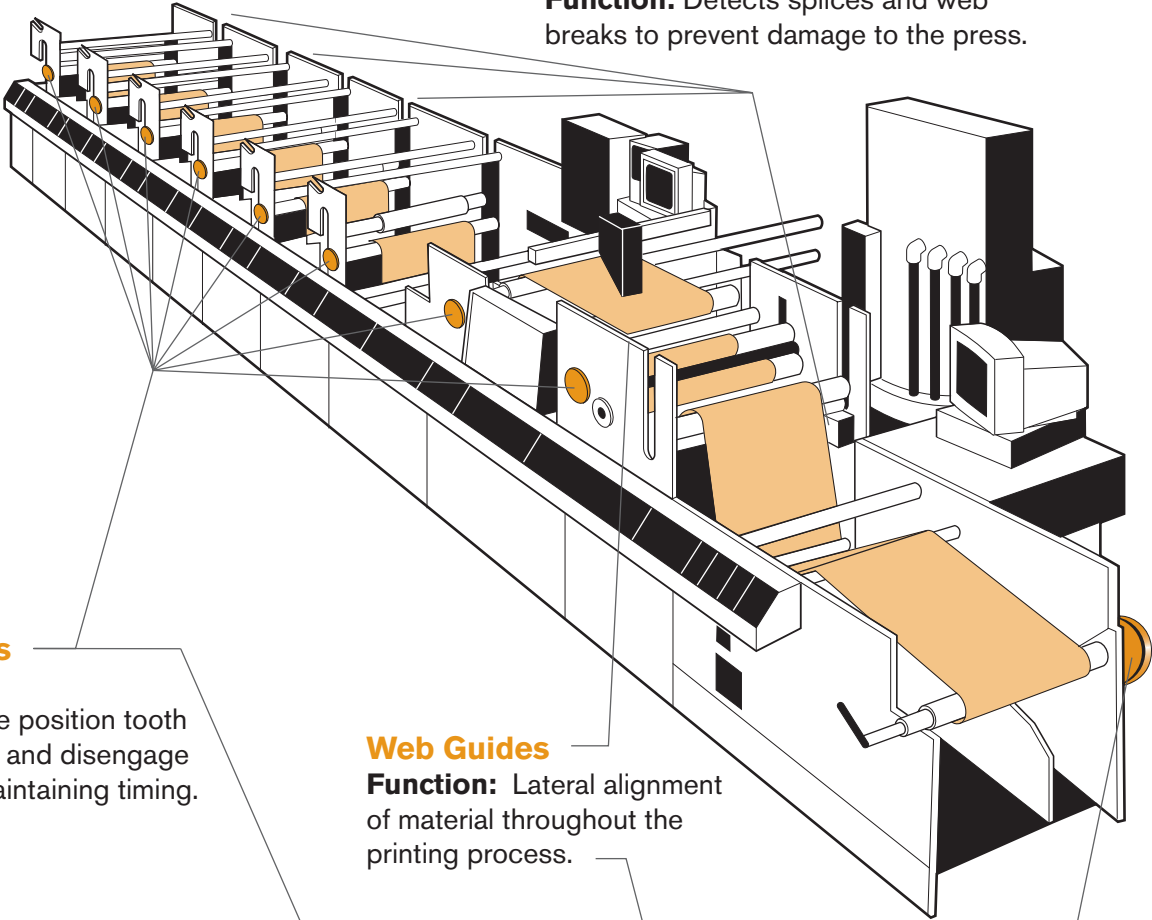

Tooth Clutches

5H Models

Function: Single position tooth clutches engage and disengage sections while maintaining timing.

Web Guides

Function: Lateral alignment of material throughout the printing process.

Tension Brakes

BTBA, XTBA, STB, SA, TA

Function: Maintains consistent tension on roll stock as material is fed onto the press.

Narrow Label Press

Die Cutting Operation

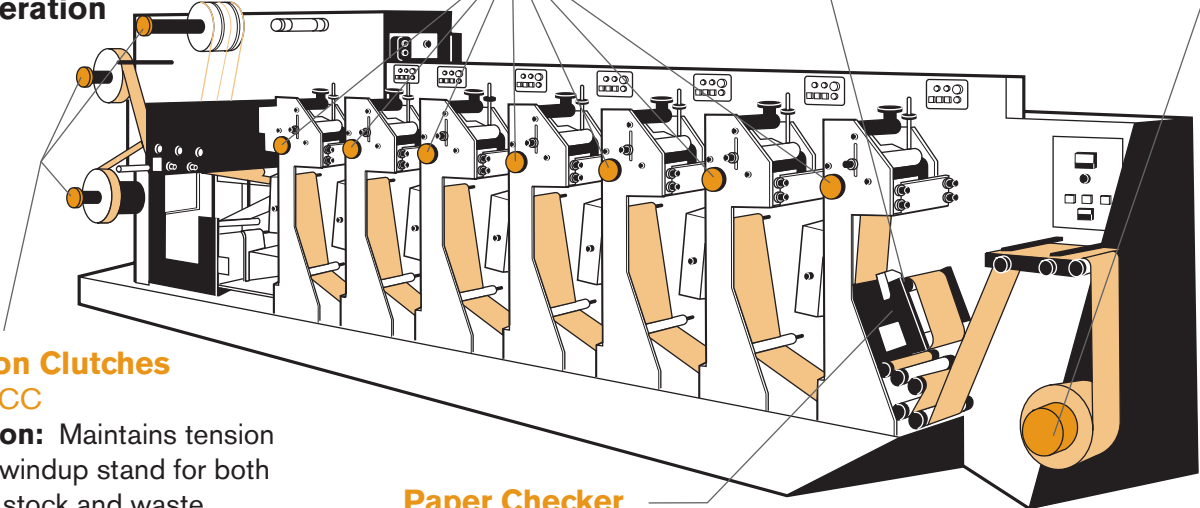

Tension Clutches

STC, TCC

Function: Maintains tension on the windup stand for both usable stock and waste.

Paper Checker
Same as above.

Web Control Products



Designed to dissipate heat away from the unit, Nexen **tension control brakes & clutches** have high thermal capacities and long operating lives. Multiple actuators allow for versatile, precise tension control. Installation and maintenance are made easy by simple connections.

Nexen offers **tension control systems** for open-loop diameter, compensating and closed-loop load cell (sensor) based tension control. Working with pneumatic brakes/clutches, these systems monitor web tension and adjust brake/clutch torque output to maintain appropriate web tension. The load cell system produces accuracy of 1-2%; the open loop system is about 8-10% accurate.



Nexen's innovative **dancer position control system** is ideal for out of round rolls, flying splice applications and multiple start/stop situations. The RSD100 Digital Dancer Controller maintains constant web tension with fast response to tension disturbances and features PC-based setup and calibration, eliminating potentiometer adjustments.



Nexen carries a variety of **web sensors** that communicate with Nexen controls for accurate web processing. Our ultrasonic sensors are perfect for edge/center control of photosensitive print paper for transparent print film. Offering sensors for splice/break detection, tension metering, line following, web guiding, and positioning, Nexen has everything you need to monitor web operations and maintain accurate positioning.

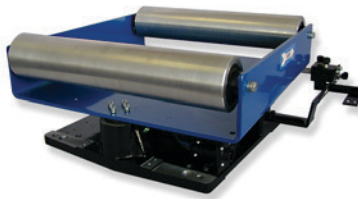

Nexen **web guiding systems** provide consistent controlled lateral alignment of the web to ensure a quality print product every time. Offering a variety of self-contained web guides and web guiding systems, we have a product to meet your unwind, intermediate, and windup guiding needs.



In accordance with Nexen's established policy of constant product improvement, the specifications contained in this document are subject to change without notice. Technical data listed in this document are based on the latest information available at the time of printing and are also subject to change without notice. For current information, please consult: www.nexengroup.com

nexen

Nexen Group, Inc.
560 Oak Grove Parkway
Vadnais Heights, MN 55127

800.843.7445
Fax: 651.286.1099
www.nexengroup.com

Nexen has sales offices throughout the United States, Europe, Japan, and Australia.

ISO 9001 Certified

©2015 Nexen Group, Inc.

21141-C-1015